

P. L. ROGERS.

TAPER BORING ATTACHMENT TO ENGINE LATHES.
No. 185,136. Patented Dec. 5, 1876.

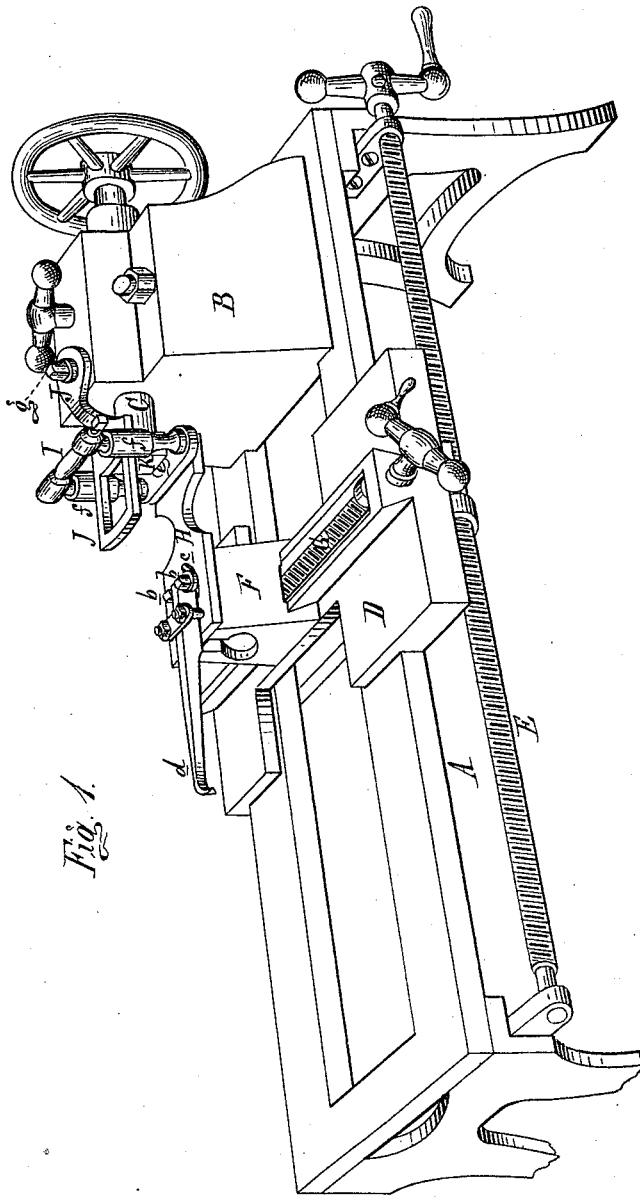

Fig. 1.

Attest:
Edward Barthel,
Charles J. Vank

Inventor:
P. L. Rogers
By Atty.
Thos. S. Sprague

P. L. ROGERS.

TAPER BORING ATTACHMENT TO ENGINE LATHES.
No. 185,136. Patented Dec. 5, 1876.

Fig. 2.

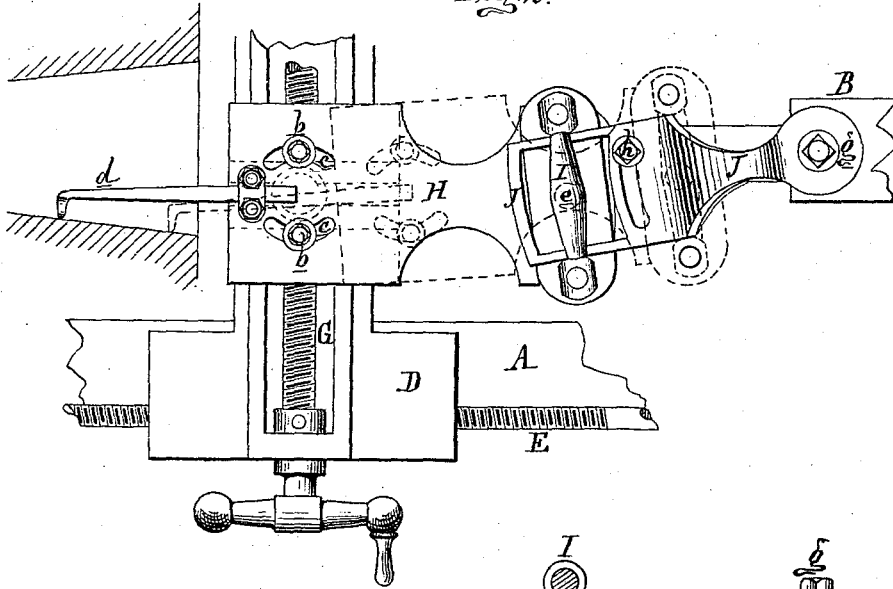
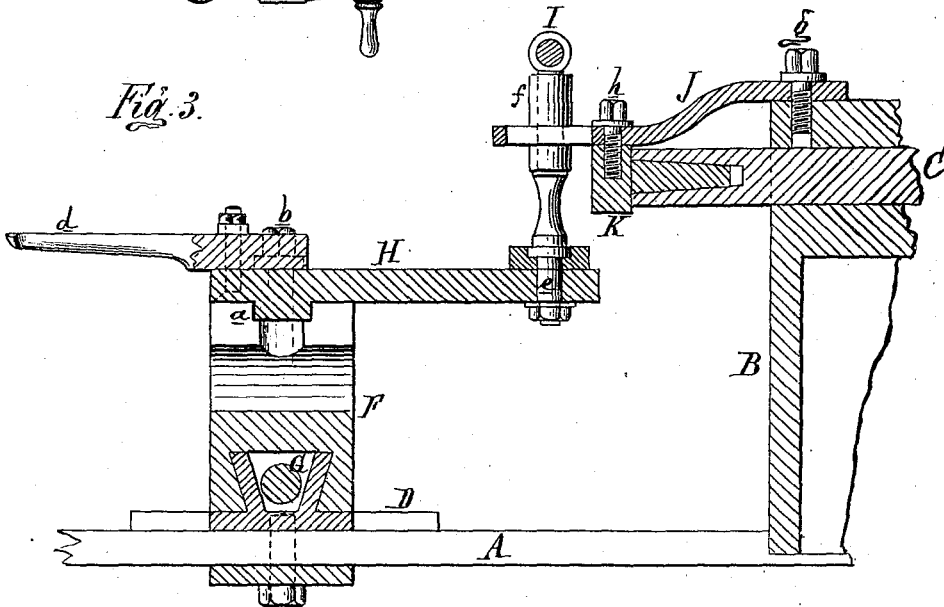

Fig. 3.



Attest:
Edward Parthel.
Charles Johnson

Inventor:
P. L. Rogers
By Atty
Wm. S. Sprague

UNITED STATES PATENT OFFICE.

PETER L. ROGERS, OF BAY CITY, MICHIGAN.

IMPROVEMENT IN TAPER-BORING ATTACHMENTS TO ENGINE-LATHES.

Specification forming part of Letters Patent No. **185,136**, dated December 5, 1876; application filed June 6, 1876.

To all whom it may concern:

Be it known that I, PETER L. ROGERS, of Bay City, in the county of Bay and State of Michigan, have invented a new and useful Attachment to Engine-Lathes for Boring Tapers, of which the following is a specification:

The object I have in view is to provide a simple, but effective and very cheap, attachment to an engine-lathe, for turning or boring holes in metal to any desired taper, consisting, merely, of a swinging tool-carrier pivoted to the traverse-stand of the carriage, with a guide-yoke pivoted to its tail end, and an adjustable guide secured to the tail-stock and tail-mandrel of the lathe, as more fully hereinafter set forth.

Figure 1 is a perspective view of an engine-lathe (omitting the head-stock) fitted with my attachment. Fig. 2 is a plan of the attachment, showing also, in outline, the positions of the parts at two points in the work. Fig. 3 is a longitudinal vertical section.

In the drawing, A represents the shears of an engine-lathe, fitted with the usual tail-stock B, tail-mandrel C, and carriage D, moved by the lead-screw E, in the ordinary way. F is the traverse-stand, moved on the carriage by the cross-feed screw G. H is a swing-plate, pivoted by a stud, *a*, on its under side into a socket in the top of the traverse-stand. At each side of the pivot segment-slots *c c* are cut in the plate, through which stud-bolts *b b* pass, and are tapped into said stand to hold the plate in position, but are not screwed tight enough to bind it, leaving it free to swing on the axis. *d* is an "inside" tool, clamped onto the swing-plate, as shown. The pivot *a* is under one end of the plate, the other extending toward the tail-stock, where it has pivoted to it, at *e*, an upright yoke, I, on each of whose side pillars is a friction-sleeve, *f*. J is a guide-

plate, fastened at one end by a set-screw, *g*, to the tail-stock, in the longitudinal axis thereof. The tail-center is removed from the tail-mandrel, and in its place is inserted a conical steady-pin at the back of a block, K, on whose head the guide-plate J rests, and to which it is adjustably secured by a set-screw, *h*, passing through a segment-slot in said plate, and tapped into said block. The sides of the guide-plate are parallel, and its width is such that it will enter between the rollers of the side pillars of the yoke, or rather that they will embrace it when moved with the carriage.

To bore a taper of a given angle, all that is required is to adjust the guide-plate to the same angle with relation to the axis and V's of the lathe; then, as the yoke moves along the guide-plate, it will swing the plate in one direction and the tool in the opposite direction, causing it to bore the hole out to the angle or taper given by the guide.

The hole may be bored from either end clear through, or partly through, and finished straight, by clamping the tool-plate and running back the tail-mandrel, so as to detach the guide-plate, and, if necessary, the work can then be "faced up." The cut of the tool can be adjusted by the traverse-screw in the usual way.

What I claim as my invention is—

In a taper-boring attachment to an engine-lathe, the combination of the tool-plate, adapted to swing on the traverse-standard, the yoke, pivoted to the tail end thereof, and the guide-plate, adapted to be adjustably secured to the tail-stock, substantially as described.

PETER L. ROGERS.

Witnesses:

H. S. SPRAGUE,
EDWARD BARTHEL.